

Rev 1.1

TEMP2 800-220-00
REDSTAR3 Dual Array Temperature Controller

Table of Contents

7.0 TEMP2 800-220-00 REDSTAR3 Dual Array Temperature Controller.....	3
7.1 Overview.....	3
7.1.1 NICI Requirements	3
7.2 Technical Specifications 800-220-00 TEMP2	3
7.3 Front Panel photo.....	4
7.4 Block Diagram	5
7.5 Functional Description 800-200-00 TEMP	7
7.5.1 Overview	7
7.5.2 Lakeshore 331/2	7
7.5.2.1 Temperature Sensor Measurement.....	7
7.5.2.2 PID control	8
7.5.2.3 Heater Resistors	9
7.5.2.4 Front Panel Information	9
7.6 Configuration and Connections.....	9
7.6.2 Configuration	9
7.6.3 RS232 Connection	9
7.6.4 Si Diode Connections	9
7.6.5 Heater Connections	10
7.6.6 AC power Connection.....	10

7.0 TEMP2 800-220-00 REDSTAR3 Dual Array Temperature Controller

7.1 Overview

The TEMP2 is a dual array temperature control and monitoring subsystem based on Lakeshore Cryotronics Model 331/2 temperature controllers plus a Model 218 Temperature monitor.

7.1.1 NCI Requirements

- 7.1.1.1 Independently control the temperature of each array to a user settable temperature approximately 30-35 degrees Kelvin +/- 0.1 degrees Kelvin.
- 7.1.1.2 The temperature not vary by more than 0.1 degrees over periods of 10 minutes. Gradual drifts of not more than 1 degree are allowed as long as the change in temperature does not exceed 0.1 degrees K/10 minute period..
- 7.1.1.3 The temperature controller shall be serially controlled and allow for readout of the temperature and modification of the set point, the servo loop PID parameters and the heater output power.
- 7.1.1.4 Temperature sensors positions will be in the following locations:

1. Array #1 mount
2. Array #2 mount
3. Cold Structure Closed Cycle Cooler first stage
4. Cold Structure Closed Cycle Cooler second stage
5. Camera cold structure (farthest point from closed cycle cooler attachment)
6. Radiation shield (farthest point from closed cycle cooler attachment)
7. Radiation Shield cooler first stage
8. APD temperature

7.2 Technical Specifications 800-220-00 TEMP2

- Lakeshore Model 331/2 Controller (see attached vendor documentation for detailed specs)
- 2 channel temperature monitor
- with Si Diode (DT-470) sensors, $\sim \pm 0.5\text{mK}$ accuracy (30K-375K)
- 24 bit ADC resolution at 10 sample/sec rate
- 2 channel PID (with manual mode) controller
- Control stability better than $\pm 0.6\text{mK}$ at 1.4K, $\pm 11\text{mK}$ at 77K
- Heater #1 50W (1Amp), 18 bit DAC, 50uV isolated output
- Heater #2 10W (1Amp), 16 bit DAC, < 0.3mV non-isolated output
- RS-232 interface

Environmental Specifications

- 15-35 °C rated accuracy, 10-40 °C reduced

Mechanical Specifications

Each Model 331/2 Temperature Controller and the Model 218 Temperature Monitor have the following dimensions

- Width: 217 mm (8.5 in)
- Height: 90 mm (3.5 in)
- Depth: 317 mm (14.5 in) plus clearance for rear connections
- Weight: 4.8 kilograms (10.5 pounds)

Model 331/2

Rev 1.1

- Weight: 4.8 kilograms (10.5 pounds)
- Model 218
- Weight: 3 kilograms (6.6 pounds)
- 3303 Output Filter
- Width: 217 mm (8.5 in)
 - Height: 90 mm (3.5 in)
 - Depth: 317 mm (14.5 in) plus clearance for rear connections
 - Weight: 1 kilograms (2.2) pounds

7.3 Front Panel photo

Note



7.4 Block Diagram

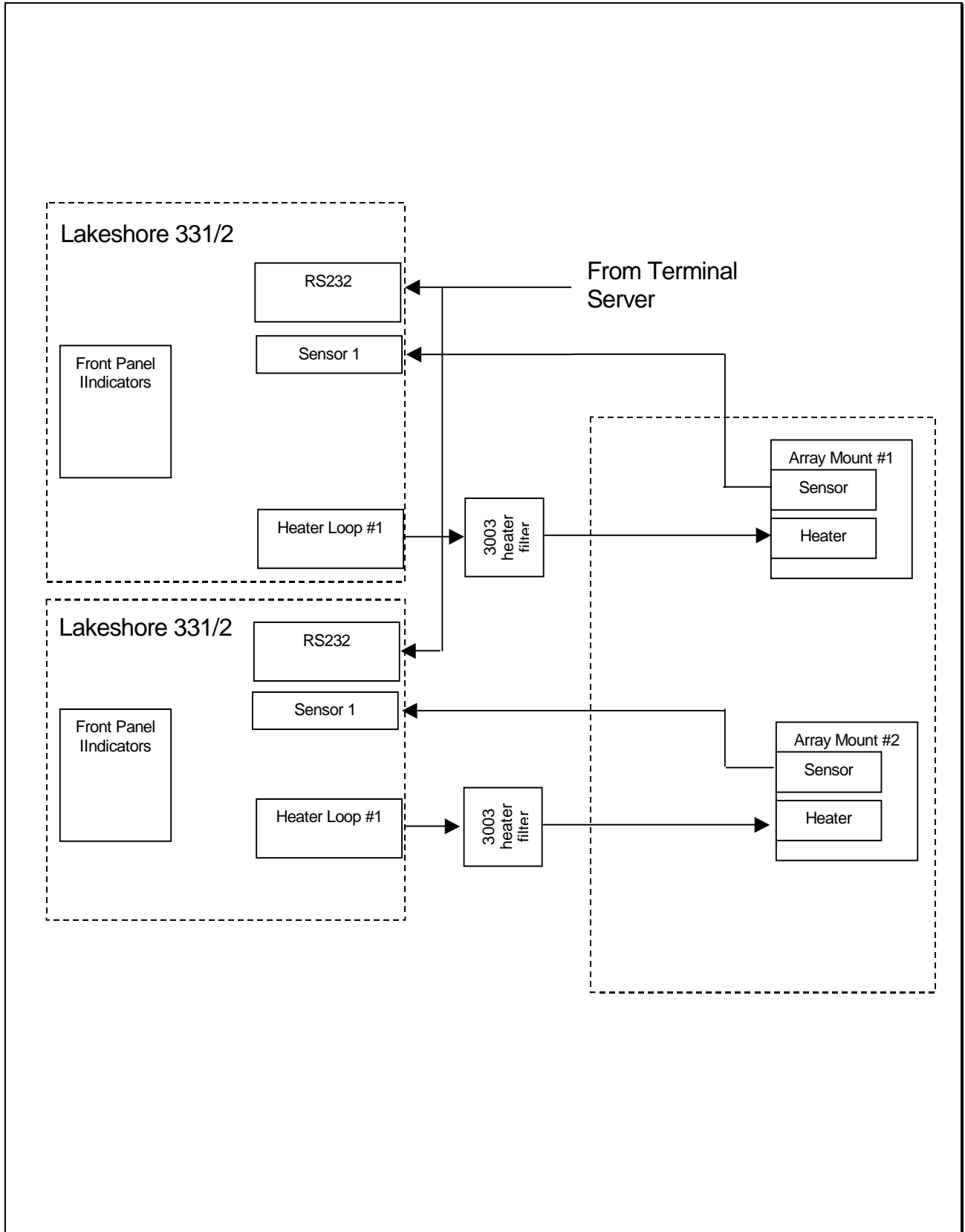

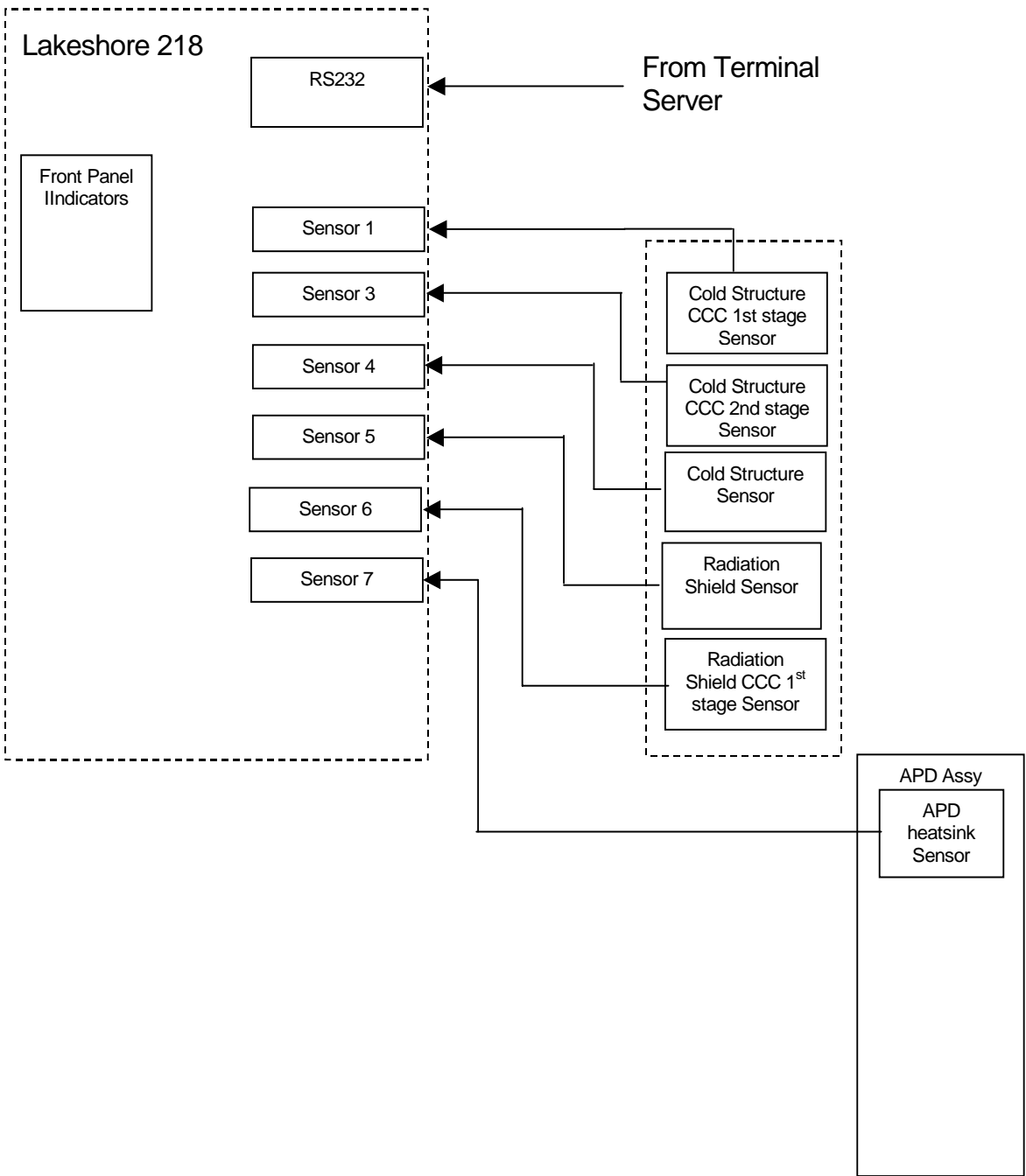

7.5 Functional Description 800-200-00 TEMP

7.5.1 Overview

Although the TEMP2 subsystem is basically a standard installation of two Lakeshore Model 331/2 controllers and Model 218 monitor, application specific information is presented here.

Two individual controllers are used to control the two infrared arrays. Each controller has 2 control loops and heater outputs. The following description details the configuration for a single array.

7.5.2 Lakeshore 331/2

The Lakeshore 331/2 controls each heater output based on PID control loop that monitors the sampled temperature derived from a 4 wire measurement of a Si diode (DT-470).

7.5.2.1 Temperature Sensor Measurement

Temperature is sensed using a 4 wire connection to a Lakeshore DT-470 Si diode . The diodes from the "standard" series (explained in the following Lakeshore diagram). The sensor is fed with a 10 μ A \pm 0.01% excitation current. A 24 bit ADC is used to sample the resulting voltage at a 10 sample/sec rate (331/2).

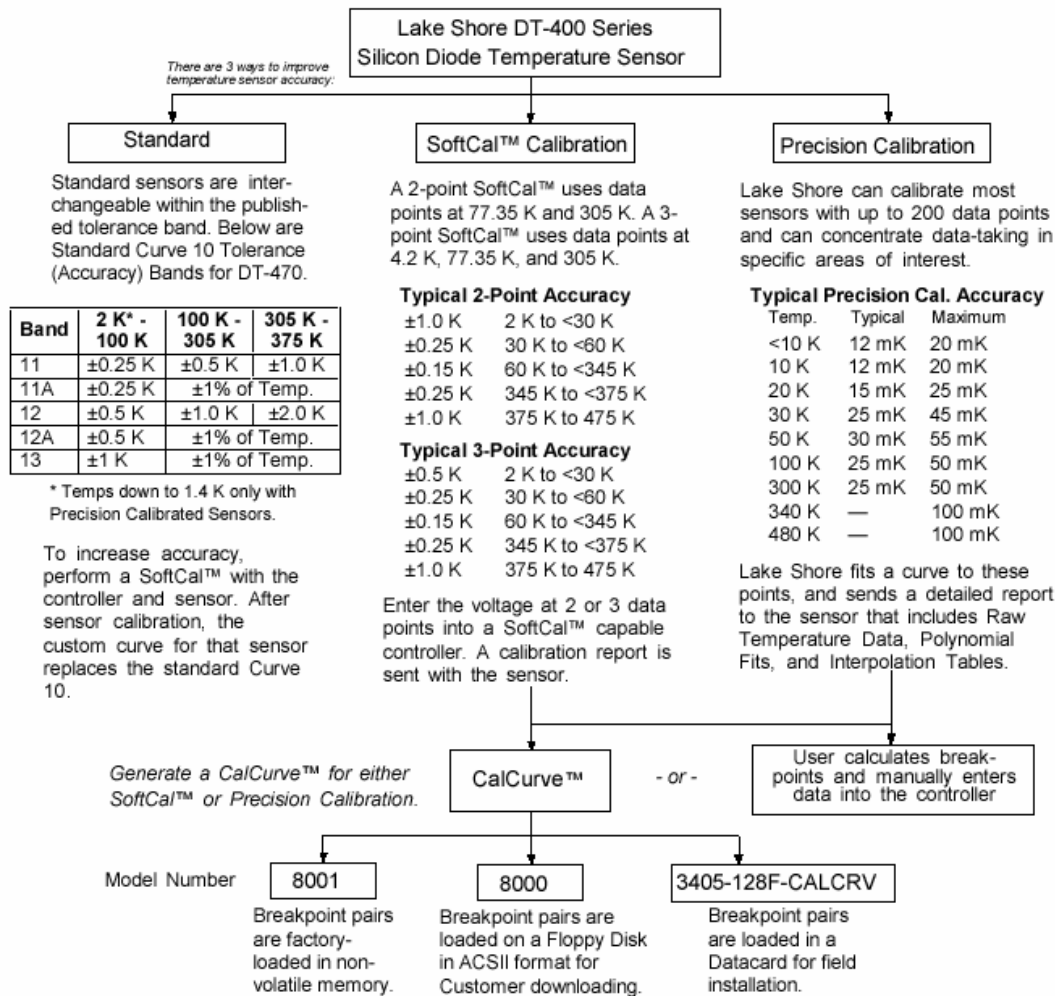

Figure 2-1. Silicon Diode Sensor Calibrations and CalCurve

7.5.2.2 PID control

Each heater output is controlled using a Proportional (P) , Integral (I) and Derivative (D) term control loop. The controller compares the set point temperature to the measured sensor temperature (at a 10 times/sec rate), computes an error, applies the PID terms and outputs a correction 18 bit (16 bit in the heater#2 case) DAC number to the heater output.

For optimal array operation it is necessary to manually tune these terms ONCE THE CRYOSTAT HAS REACHED THERMAL OPERATIONAL EQUILIBIUM. The AUTOTUNE feature can produce adequate settings (again only after the cryostat has reach equilibrium), but experience has shown that manual settings produce the best results. Consequently, it is best to start with the “default” settings obtained during system integration and make minor adjustments around these number on the telescope. The default settings are:

DEFAULT SETTINGS as of xx/xx/xx

```
ARRAY#1
P = ###
I = ###
D = ###
ARRAY#2
P = ###
I = ###
D = ###
```

Refer to page ## of the attached Lakeshore manual to repeat the tuning procedure and detailed explanation. It should not be necessary (nor recommended) to repeat the Lakeshore manual tuning procedure, but for quick reference, the following section has been copied from the Lakeshore manual.

2.7.2 Tuning Proportional

The proportional setting is so closely tied to heater range that it can be thought of as fine and course adjustments of the same setting. An appropriate heater range must be known before moving on to the proportional setting.

Begin this part of the tuning process by letting the cooling system cool and stabilize with the heater off. Place the Model 332 in Manual PID control mode, then turn integral, derivative and manual output settings off. Enter a setpoint several degrees above the cooling systems lowest temperature. Enter a low proportional setting of approximately 5 or 10 and then enter the appropriate heater range as described above. The heater display should show a value greater than zero and less than 100%. The load temperature should stabilize at a temperature below the setpoint. If the load temperature and heater meter swing rapidly, the heater range may be set too high and should be reduced. Very slow changes in load temperature that could be described as drifting are an indication of a proportional setting that is too low (which is addressed in the next step). Gradually increase the proportional setting by doubling it each time. At each new setting, allow time for the temperature of the load to stabilize. As the proportional setting is increased, there should be a setting in which the load temperature begins a sustained and predictable oscillation rising and falling in a consistent period of time. The goal is to find the proportional value in which the oscillation begins, do not turn the setting so high that temperature and heater output changes become violent. Record the proportional setting and the amount of time it takes for the load change from one temperature peak to the next. The time is called the oscillation period of the load and it helps describe the dominant time constant of the load which is used in setting integral. If all has gone well, the appropriate proportional setting is one half of the value required for sustained oscillation. If the load does not oscillate in a controlled manner, the heater range could be set too low. A constant heater reading of 100% on the display would be an indication of a low range setting. The heater range could also be too high, indicated by rapid changes in the load temperature or heater output with a proportional setting of less than 5. There are a few systems that will stabilize and not oscillate with a very high proportional setting and a proper heater range setting. For these systems, setting a proportional setting of one half of the highest setting is the best choice.

Rev 1.1

7.5.2.3 Heater Resistors

The array mounts have integral (epoxied) heater resistors embedded in a channel in on the backside of the front cold plate. There are four 100Ohm resistors arranged in a parallel pairs and brought out of the cryostat on four conductors. The 50Ohm loads are then tied in series at the heater filter into a 100 Ohm equivalent load.

7.5.2.4 Front Panel Information

The front panel displays the measured temperature, set point and percentage heater output for each control



loop. Although it is possible for set points to be entered via the front panel, array controller software will program the values via the RS232 interface. Consequently, the front panel buttons should only be used in an engineering capacity.

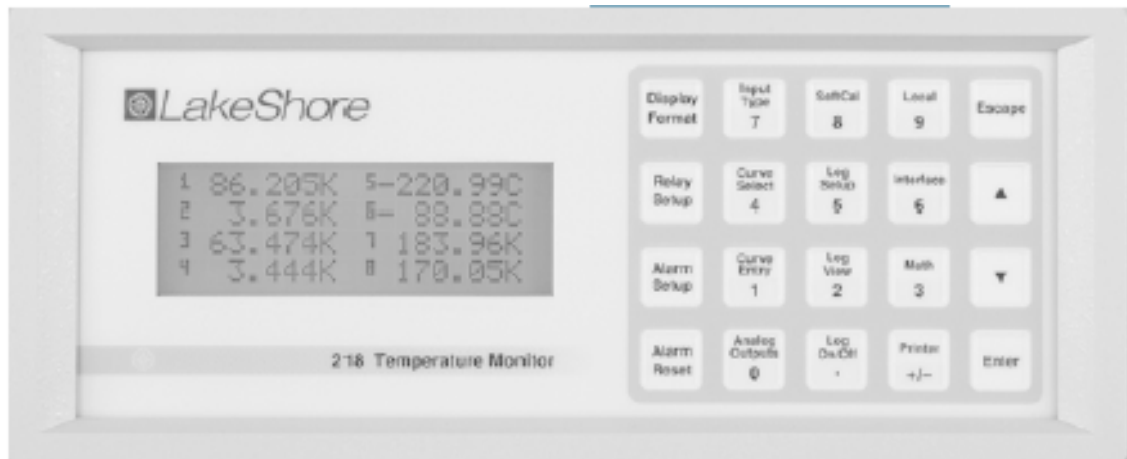

7.6 Configuration and Connections

7.6.2 Configuration

All operational configuration issues should be configured by the instrument control software via the RS232 interface. Refer to the Software Operation Manual for details.

7.6.3 RS232 Connection

The TempCont (#1 or #2) cable connects to the DE-9 RS232 connectors on the rear panel of the controllers and monitor. The interface does not use hardware handshaking.

7.6.4 Si Diode Connections

Rev 1.1

The Si Diodes connect to the Model 331/2 controller INPUT A and INPUT B rear panel connectors with the DIN6 cables.

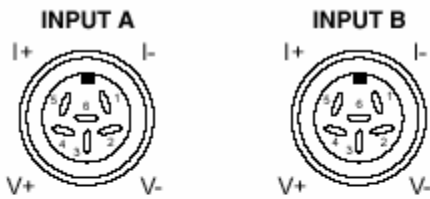

PIN	SYMBOL	DESCRIPTION
1	I-	- Current
2	V-	- Voltage
3	none	Driven Shield or Guard
4	+V	+ Voltage
5	+I	+ Current
6	none	No Connection

The Si diodes connect to the Model 218 monitor via the rear panel DB25 connector (figure #5).

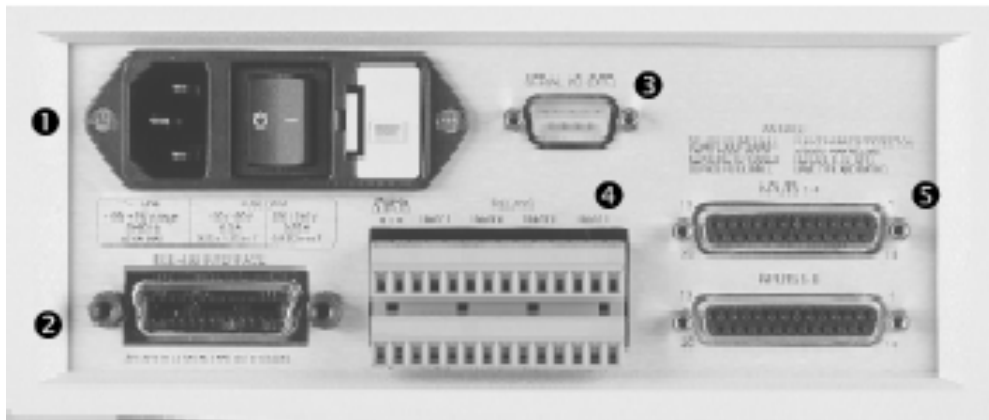

7.6.5 Heater Connections

The array mount heater resistors connect to the controller via prewired 3003 filter assemblies.



PIN	DESCRIPTION
1	HI
2	LO
3	SHIELD

7.6.6 AC power Connection

A standard 3 pronged 120VAC connector should be cabled to the appropriate Baytech power control unit.