

# GEMINI

## Near Infrared Coronagraphic Imager (NICI)

SDN3004

### **Mechanism Control Subsystem Electronics Specification**

Rev 0.91

**MKIR# NICI-800-601-00**

Last Modified 11/03/2004

**PRELIMINARY**

**ABSTRACT:** This document provides an overview and detailed technical specifications of NICI's Mechanism Control Subsystem which is part of the Instrument Control Electronics. This document is part of the NICI Service & Calibration Manual.

Prepared by [Mauna Kea Infrared](#)

**Revision History**

Revision	Author	Summary of revisions	Date
0.91 PRELIM	<a href="#">Mike Thompson</a>	Prepared for preliminary release to customer.	11/03/04
0.1	Peter Onaka	Initial Revision.	2/11/02

**Table of Contents**

**1 Introduction ..... 4**

1.1 Reference Documents.....4

1.2 Mechanism Control Overview .....5

**2 Technical Specifications ..... 6**

**3 Functional Description ..... 7**

3.1 Mechanism Utility Box (UBox) .....7

3.2 Junction Box (JBox).....9

**4 Mechanism Control Cabling ..... 10**

4.1 Cable Descriptions .....10

4.1.1 Mechanism Utility Cable Description.....10

4.1.2 Cryostat Motors' Animatics Cables Description .....10

4.1.3 Hall Effect Utility Cable Description.....10

4.1.4 AO Mechanism Cables Description .....10

4.1.5 Calibration Cable Description.....10

4.1.6 FSM Cable Description .....10

4.2 Cable Specifications .....11

**5 System Grounding ..... 12**

**6 Acronyms and Definitions ..... 12**

**Table of Figures**

Figure 1 Mechanism Control Subsystem High Level Block Diagram .....5

Figure 2 Block Diagram of Utility Box Components and Interfaces .....8

Figure 3 Block Diagram of JBox Components and Interfaces .....9

# 1 Introduction

Gemini's NICI instrument contains a number of mechanisms and calibration sources. NICI's Instrument Controller Electronics implement the hardware and software necessary for controlling and powering all of the mechanisms and calibration sources.

This is the electronics specification for the NICI Instrument's Mechanism Control Subsystem. This specification is useful for setting up the Motor Control Subsystem, troubleshooting motors and mechanisms, and is an engineering reference document.

## 1.1 Reference Documents

There are several documents and addendums that may be referenced when considering the Mechanism Control Subsystem.

- NICI User Manual
- NICI Service & Calibration Manual
- Temperature Control Subsystem Specification
- Mechanism Control Specification Addendums
  - UBox Specification
  - JBox Specification
  - System Spreadsheet Book / Mechanism - Hall Effect Wiring Spreadsheet

The Addendums to this specification are included in the print and PDF versions of this document as part of this Mechanism Control Subsystem Specification.

### 1.2 Mechanism Control Overview

The Mechanism Control Subsystem is a part of NICI's Instrument Control electronics. The subsystem is responsible for controlling and providing power to the motors that drive NICI's mechanisms.

Control of the mechanisms flows from the software running in the Instrument Control (IC) Server through a Terminal Server and to the Mechanism Utility Box (UBox). The Utility Box takes the serial control lines from the terminal server and combines them with power from the Animatics Power Supply in the Mechanism Utility Cable for the cryostat mechanisms and in AO Mechanism cables for the AO mechanisms.

The UBox also provides hardware for driving calibration sources and the Field Steering Mirror (FSM) in the AO Bench over the Calibration Cable and FSM cables.

The Junction Box (JBox) acts as a fan-out for the motor control and power signals from the Mechanism Utility Cable to the Cryostat Motors. The JBox also interfaces with the Hall Effect circuitry on the cryostat mechanisms for detecting mechanism positions.

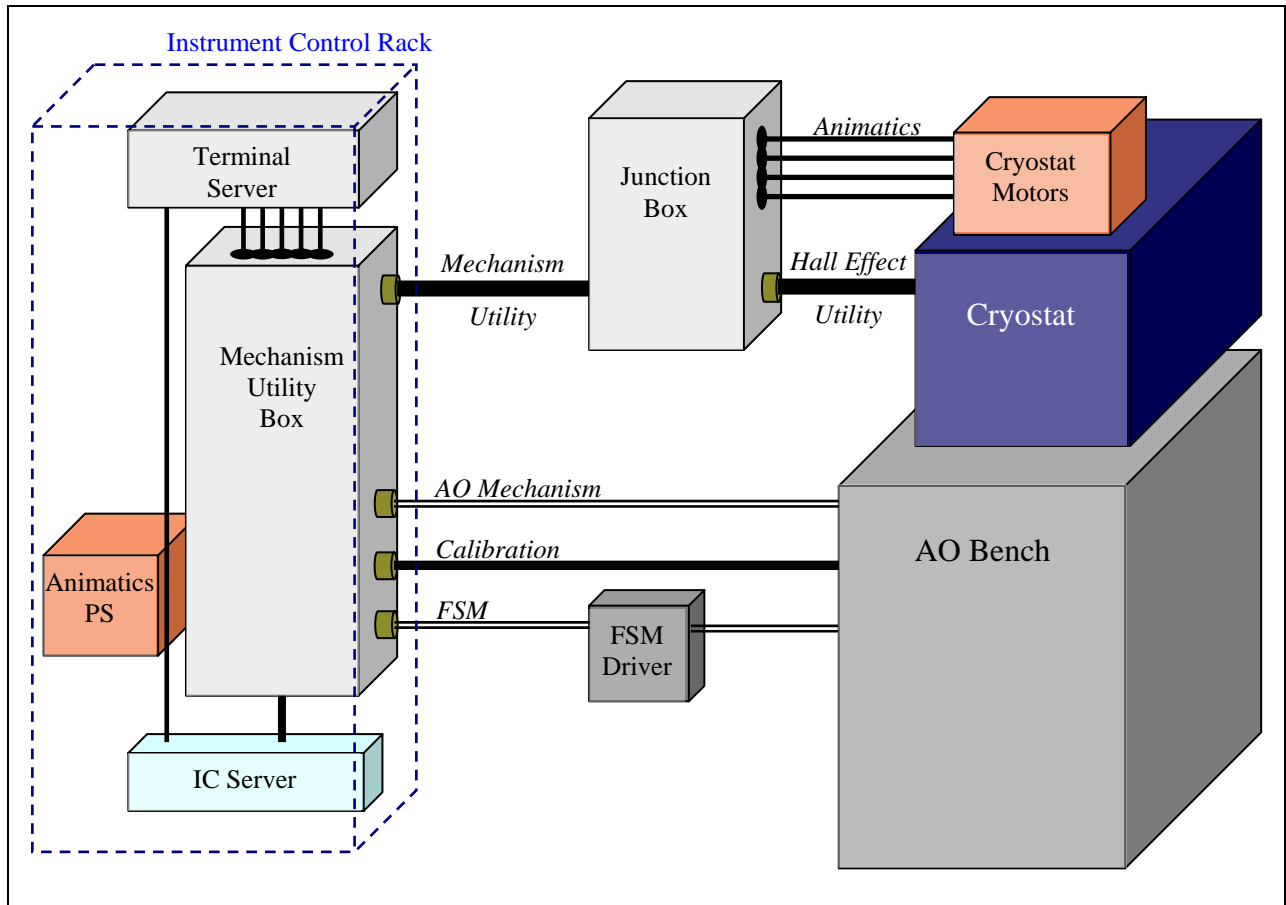

Figure 1 Mechanism Control Subsystem High Level Block Diagram

## 2 Technical Specifications

This section provides a quick overview of the technical features and components of the Mechanism Control Subsystem. For additional details on the design and implementation, see the specifications of lower level documentation. Mechanical and electrical specifications are specified in the Service & Calibration Manual.

- **Instrument Control Rack:**
  - **Mechanism Utility Box (UBox):** Provides an interface between the IC Server and Terminal Server for powering and controlling NICI's mechanisms and calibration sources.
  - **Terminal Server:** Serves serial ports for the IC Server's software to control mechanisms and calibration sources.
  - **Instrument Control Server:** Part of the IC Server's functionality is dedicated to driving mechanism control.
  
- **Junction Box (JBox):**
  - Provides a fan-out location for motor serial control and power signals on the cryostat assembly.
  - Also houses the mechanisms' Hall-Effect monitoring circuitry.
  - Houses Sixnet Electronics for driving analog and digital voltages to the calibration sources and FSM Controller.
  
- **Cryostat Motors & Mechanisms:**
  - Seven motors are mounted on and around the cryostat assembly for moving seven cryostat mechanisms.
  - Each motor is controlled and powered by a single cable.
  - The mechanisms are configured with Hall-Effect sensors for discrete and continuous position monitoring. Most of these mechanisms are dedicated to the science optics.
  
- **AO Bench:** There are several mechanisms and calibration sources housed in the Adaptive Optics Bench. The Motor Control Subsystem provides power and control to these mechanisms.
  - **Motors & Mechanisms:**
    - Neutral Density Filter Wheel
    - Fiber Calibration Slide
  - **Calibration Sources**
    - IR Calibration Source (also 2 Fiber Cal. Source)
    - Laser Calibration Source
  - **Field Steering Mirror (FSM)**
  
- **Mechanisms:** Nine mechanisms are controlled. This list of mechanisms indicates the planned implementation. Refer to the NICI User Manual for final implementations.

Mechanism	Type of Drive
Pupil Mask Wheel	Discrete position wheel
Beam Splitter/Dichroic Wheel	Discrete position wheel
Red (CH1) Filter Wheel	Discrete position wheel
Blue (CH2) Filter Wheel	Discrete position wheel
Pupil Imager Wheel	Discrete position wheel
Focal Plane Mask Wheel	Continuous rotary drive
Spider Mask Rotator	Continuous rotary drive
AO ND Filter Wheel	Discrete position wheel
AO Fiber Calibration Slide	Continuous slide

## 3 Functional Description

### 3.1 Mechanism Utility Box (UBox)

The Mechanism Utility Box is a rack-mounted enclosure that centralizes the electronics for controlling NICI's mechanisms and calibration sources and houses the Cryostat Temperature Monitor. A block diagram of the Mechanism Utility Box is provided in Figure 2.

For controlling mechanisms the UBox combines IC Server driven serial control lines from the Terminal Server and combines them with power from the Animatics Power Supply in a custom designed 55-pin Mechanism Utility Cable. The Mechanism Utility Cable contains all of the power and control signals for driving the Cryostat Motors. Power and control for two mechanisms in the AO Bench are also driven from the UBox over two AO Mechanism Cables to the AO Bench.

The UBox also drives the Calibration Cable to the AO Bench for controlling the IR Calibration Source. IC Software controls the IR Calibration Source via a serial line from the Terminal Server.

The command and readout lines for the Field Steering Mirror in the AO Bench are driven over the FSM cable. Software can control the command lines and monitor the readout lines via the Ethernet LAN.

A Lakeshore 318S Temperature Monitor is mounted the UBox with interfaces to the Cryostat's temperature sensors and to the Lakeshore 332S Temperature Controllers in the IC Rack. For more information on the Temperature Control Subsystem, see the Temperature Control Subsystem Specification.

The Utility Box is described in greater detail in the NICI Utility Box Specification.

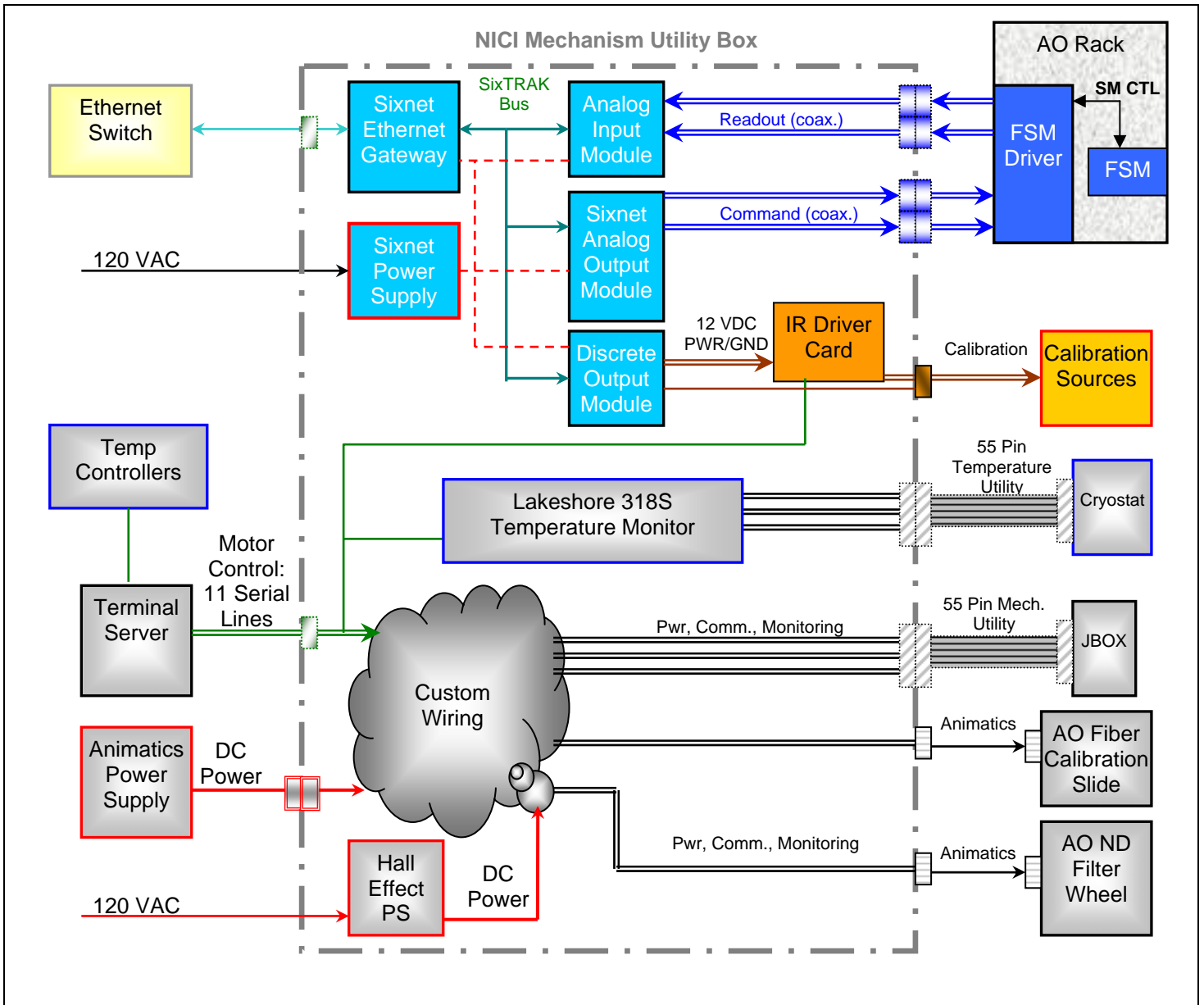

Figure 2 Block Diagram of Utility Box Components and Interfaces

### 3.2 Junction Box (JBox)

The JBox has two major functions. One is to act as a junction box to fan-out power and control signals from the 55-pin Mechanism Utility Cable to the 7 NICI Cryostat Motors' Animatics Cables.

The JBox also functions to house the Hall Effect Sensor Preamplifier Board (HEPB). The HEPB tracks the positions of the mechanisms by monitoring the Hall Effect sensors mounted on the cryostat's mechanisms via the Hall Effect Utility Cable. The HEPB provides indications to software and to the motors when the mechanisms are in a detent position. LEDs on the JBox indicate the positions of the motors.

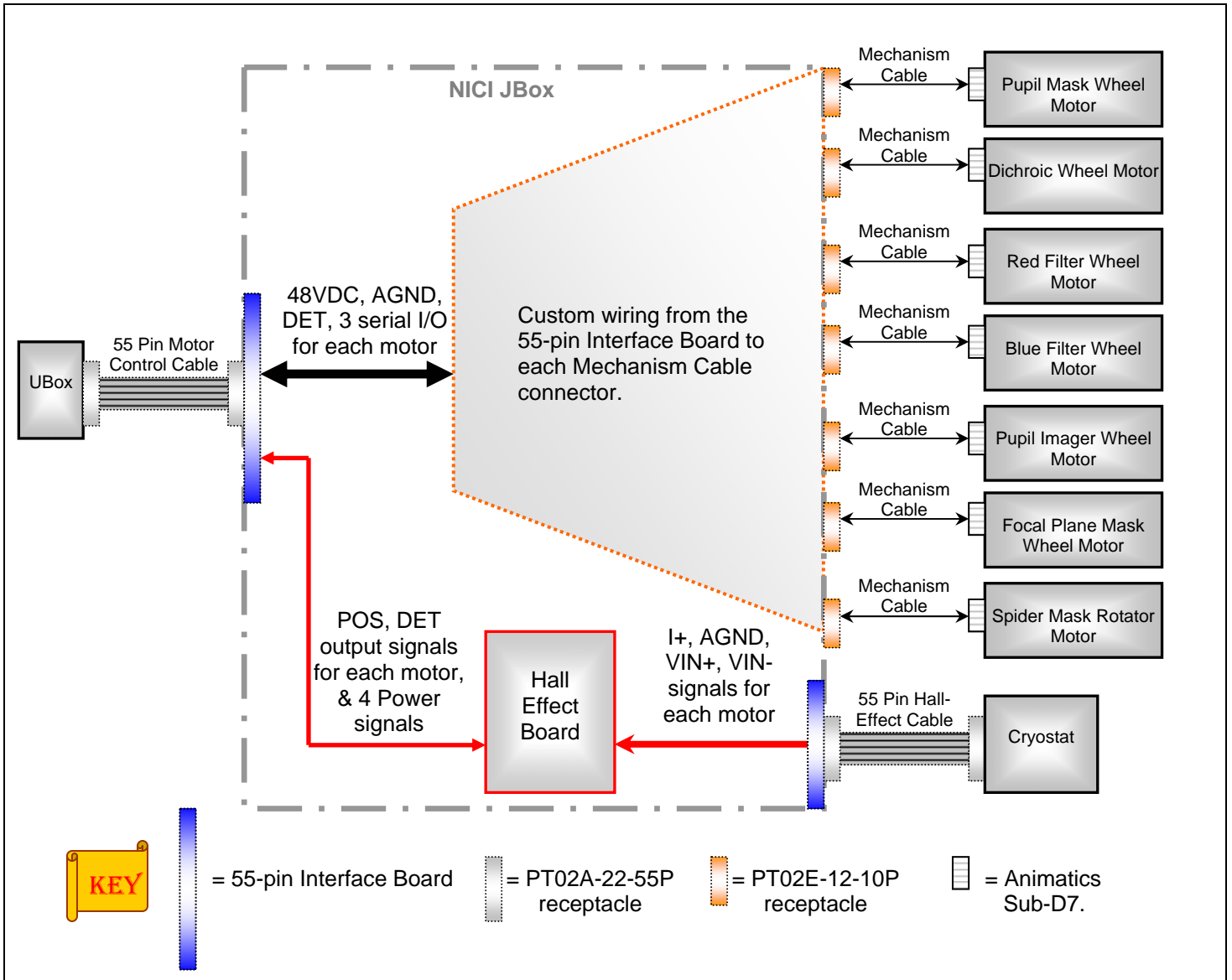

Figure 3 Block Diagram of JBox Components and Interfaces

## 4 Mechanism Control Cabling

This section defines the external connections and cabling for NICI's Mechanism Control Subsystem. The reader may refer to the block diagram in Figure 1 for the cables defined in this section.

This section is meant to provide a high level view of the cabling. Greater detail can be found in the Mechanism/Hall Effect wiring spreadsheet which defines connectors, lengths, and I/O.

The following cables are part of the

- Mechanism Utility
- 7 Cryostat Motors' Animatics
- Hall-Effect Utility
- 2 AO Mechanism
- Calibration
- FSM

### 4.1 Cable Descriptions

This section provides general descriptions and implementation details for each of the Utility Box's internal and external connections.

#### 4.1.1 Mechanism Utility Cable Description

The Mechanism Utility Cable main function is to route power and control signals for NICI's Cryostat Motors. Signals from 7 serial lines, the Animatics Power Supply, and Hall Effect Power Supply are bundled into a standard 55-pin Utility Cable with mil-spec cylindrical connectors. The cable connects to the UBox in the IC Rack, passes through a cable clamp on the IC Thermal Enclosure and connects to the JBox mounted on the Vacuum Jacket/Cryostat assembly.

#### 4.1.2 Cryostat Motors' Animatics Cables Description

The JBox fans out the power and control signals for the Cryostat Motors to the Cryostat Motors' Animatics Cables. These are off-shelf Animatics Sub-D7 cables with custom mil-spec cylindrical connectors on the JBox side. The cables connect to the JBox on one side and to Cryostat Motors on the other side.

#### 4.1.3 Hall Effect Utility Cable Description

The Hall Effect Utility Cable routes Hall Effect Sensor signals from the Cryostat Assembly to the JBox. This is a standard 55-pin Utility Cable.

#### 4.1.4 AO Mechanism Cables Description

The AO Mechanism Cables provide power, control, and monitoring of the AO Fiber Calibration Slide and AO ND Filter Wheel mechanisms and motors. These signals are bundled in the IC Rack's UBox. The cable connects to the IC Thermal Enclosure and the AO Bench.

#### 4.1.5 Calibration Cable Description

The Calibration Cable provides power signals to the AO Bench's IR Calibration Source (2 fiber) and the Laser Calibration Source from the IC Thermal Enclosure to the AO Bench.

#### 4.1.6 FSM Cable Description

The Field Steering Mirror Cables consist of three different cables. A long Sub-D9 serial cable in conjunction with a 9-pin Mini-DIN converter are used to provide power to the FSM Driver from the IC Thermal Enclosure. A Sub-D15 / BNC (video) cable carries position command and readout signals between the FSM Driver and IC Enclosure. A long Sub-D15 cable routes control signals from the FSM Driver to the AO Bench.

## 4.2 Cable Specifications

The table below provides details on each external cable used in the Mechanism Control Subsystem. The reader may refer to the block diagram in Figure 1 for the cables discussed in this section.

Cable Name	Manuf./Part/Length	Conductors	Signal Type	Connectors
Mechanism Utility	Standard Utility Glenair ABC55495, Neoprene Jacket. 92"	55 x 22 AWG	Low level/noise, 48 VDC	PT06A-22-55S molded connectors.
Cryostat Motors' Animatics	Custom built with off- shelf Animatics pig-tail cable CBLPWRCOM.	7 26 AWG Com 14 AWG PWR	Power, Serial, Shield.	Animatics Sub-D7, PT06E-12-10S
Hall Effect Utility	Standard Utility Glenair ABC55495, Neoprene Jacket.	55 x 22 AWG	Low level/noise	PT06A-22-55S molded connectors.
AO Mechanism	Custom built with off- shelf Animatics pig-tail cable CBLPWRCOM.	7 26 AWG Com 14 AWG PWR	Power, Serial, Shield.	Animatics Sub-D7, PT06E-12-10P
Calibration	Custom.	4 x 20 AWG	Power.	2 x PT06E-10-5P
FSM Control	2 row Sub-D15 Video: Sub-D15 - BNC Sub-D9	various	Low noise, shielding.	Various

## 5 System Grounding

This section is intended to provide a general description of the grounding concerns with the Mechanism Control Subsystem. The UBox itself should be grounded to PWR Neutral (the green wire). The Steering Mirror control lines and Calibration Source lines float. No grounding plans should be altered.

## 6 Acronyms and Definitions

FSM	Field Steering Mirror
IC	Instrument Control, usually refers to the IC Rack or the IC Server.
JBOX	Junction Box, a utility box primarily for interfacing with NICI's mechanisms.
UBox	The Mechanism Utility Box, for mechanism control wiring, temperature monitoring, and driving calibration sources..