

Gemini Near Infrared Coronagraphic Imager
Custom ('Cryostat-mounted') Array Electronics
GEMINI SDN3005

MKIR# NICI -800-230-00
Rev 0.1 (prerelease)
Last Modified 2/11/2002



Table of Contents

- 1 NICI Custom ('Cryostat-mounted') Array Electronics,800-230-00 3**
- 1.1 Overview.....3
- 1.1.1 Purpose.....3
- 1.1.2 Nomenclature Note: 'Cryostat Mounted'3
- 1.2 Subsystem Document Tree.....3
- 1.3 Technical Specifications Dual array REDSTAR3 Cryostat Mounted Electronics4
- 1.4 Block Diagram #15
- 1.5 Cryostat Mounted Electronics Chassis.....5
- 1.5.1 Cryostat Mounted Electronics Chassis Photo5
- 1.6 Cryostat Mounted Electronics Input/Output.....7
- 1.6.1 Cryostat Mounted Electronics Chassis Top Connector View.....7
- 1.6.2 Fiber Links.....8
- 1.6.3 Array Cables8
- 1.6.4 Input Power Connection.....9

1 NICI Custom ('Cryostat-mounted') Array Electronics,800-230-00

1.1 Overview

1.1.1 Purpose

This document provides a subsystem level description of the custom array control electronics part of the Gemini NICI instrument. The system will use a Redstar3 design configured for dual AladdinIII control. This document has been created to account for configuration and implementation details specific to NICI that may not already be covered by the Redstar3 Array Controller documents.

NOTE: This document is in prerelease form and will be updated to represent the "as built" configuration before release.

1.1.2 Nomenclature Note: 'Cryostat Mounted'

The term name 'Cryostat Mounted Electronics' is used throughout the documentation because that is the standard location for this portion of the system. This is done for low noise grounding and shielding purposes. Due to the close proximity of the Instrument Control, Rack#1 to the cryostat in NICI and the cooling requirements for the instrument, this subassembly will be located in Rack#1.

1.2 Subsystem Document Tree

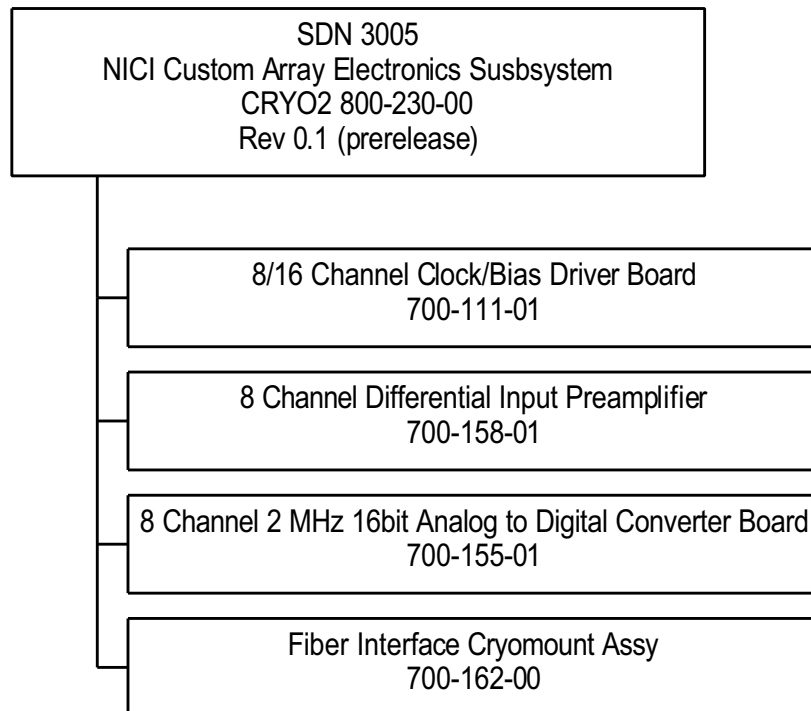

1.3 *Technical Specifications Dual array REDSTAR3 Cryostat Mounted Electronics*

- Low noise drive and readout of 2 Aladdin III arrays
- Custom 'Cryostat Mounted' Readout Electronics, SDN 3005, 800-230-00
 - 32/16 channel analog clock signal drivers
 - 32 low noise preamplifiers
 - 32 individual 2Mhz 16bit Analog to Digital Converters
 - Systran SL240 2.5Gbps (247MByte/sec) FibreXtreme FPDP interface
 - 2 Embedded Brightstar Engineering IPengine1's
 - 48Mhz PowerPC
 - Altera FPGA
 - ELINUX OS
 - 10BT Ethernet

1.4 Block Diagram #1

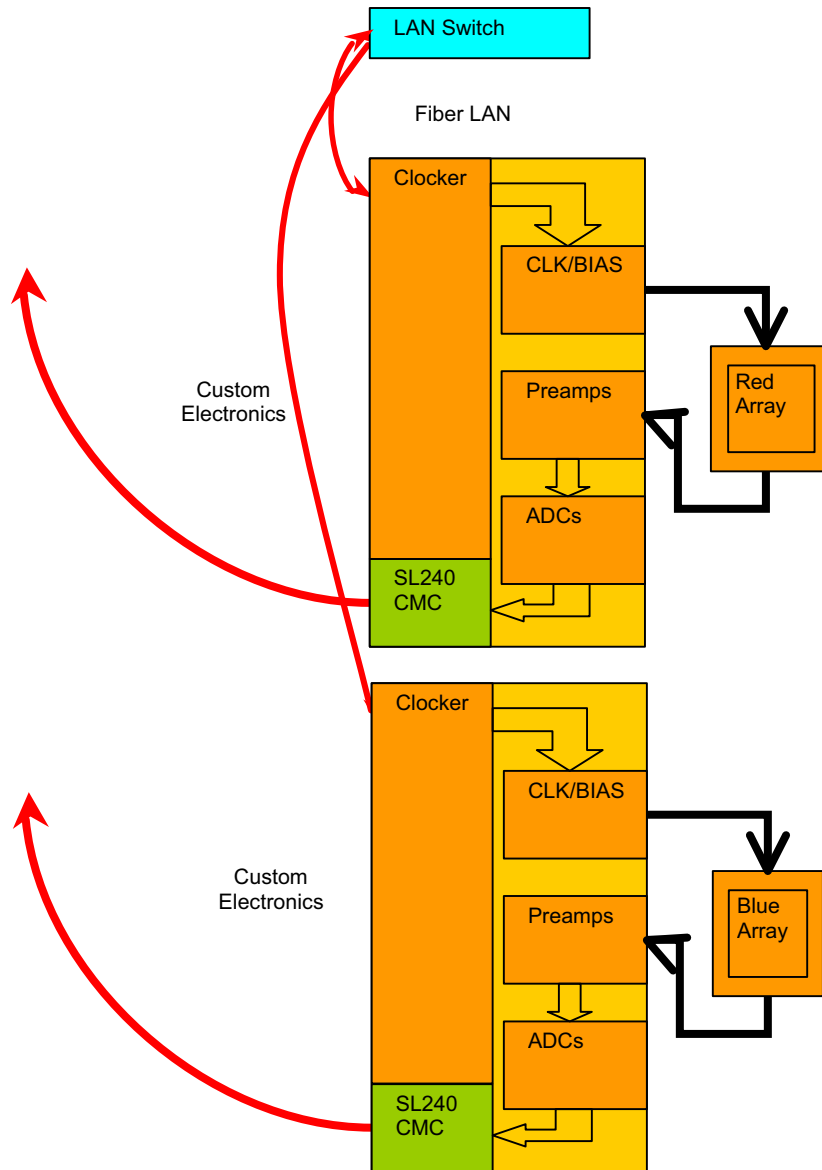

1.5 Cryostat Mounted Electronics Chassis

A 63HP Eurocard Chassis houses a set of custom low noise array readout electronics that provides up to 32 channels of analog clock drivers and 32 channels of preamplifiers and 16 bit 2Mhz analog to digital converters.

1.5.1 Cryostat Mounted Electronics Chassis Photo

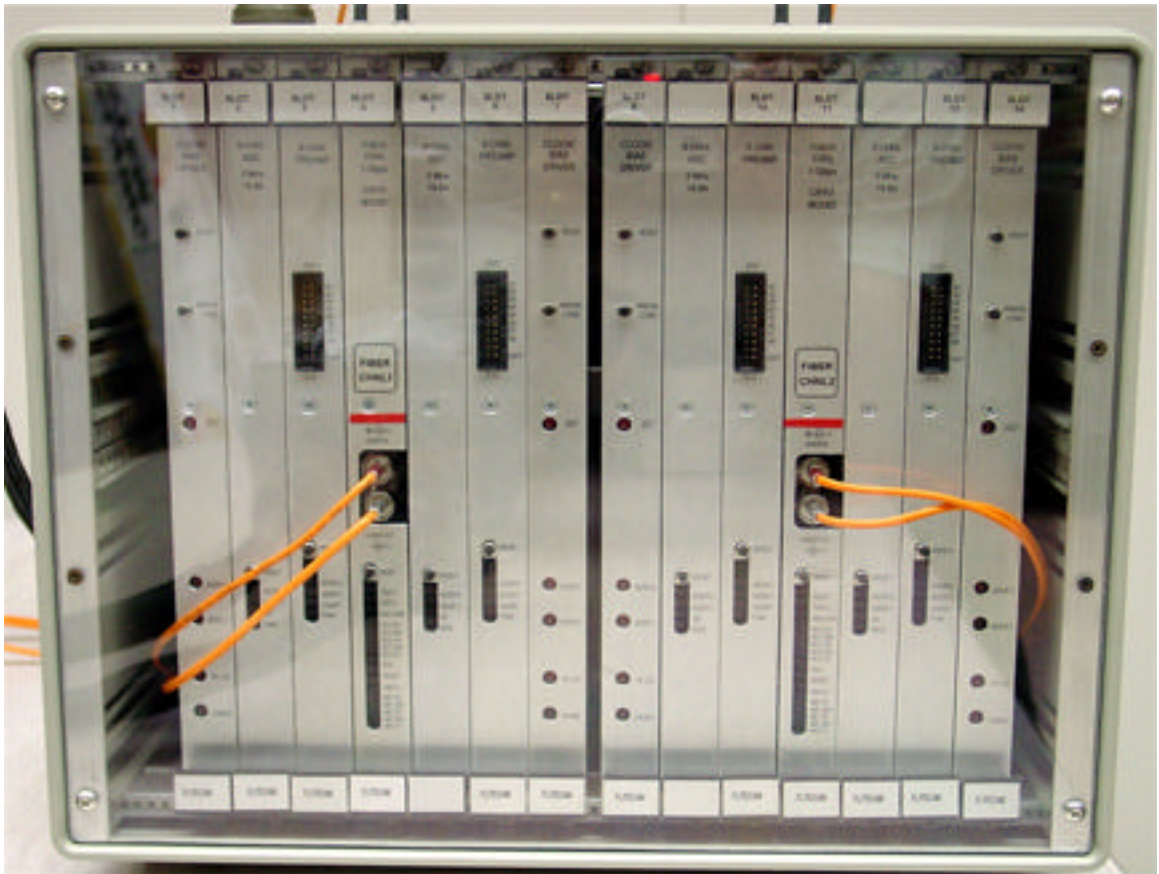

1.6 Cryostat Mounted Electronics Input/Output

1.6.1 Cryostat Mounted Electronics Chassis Top Connector View

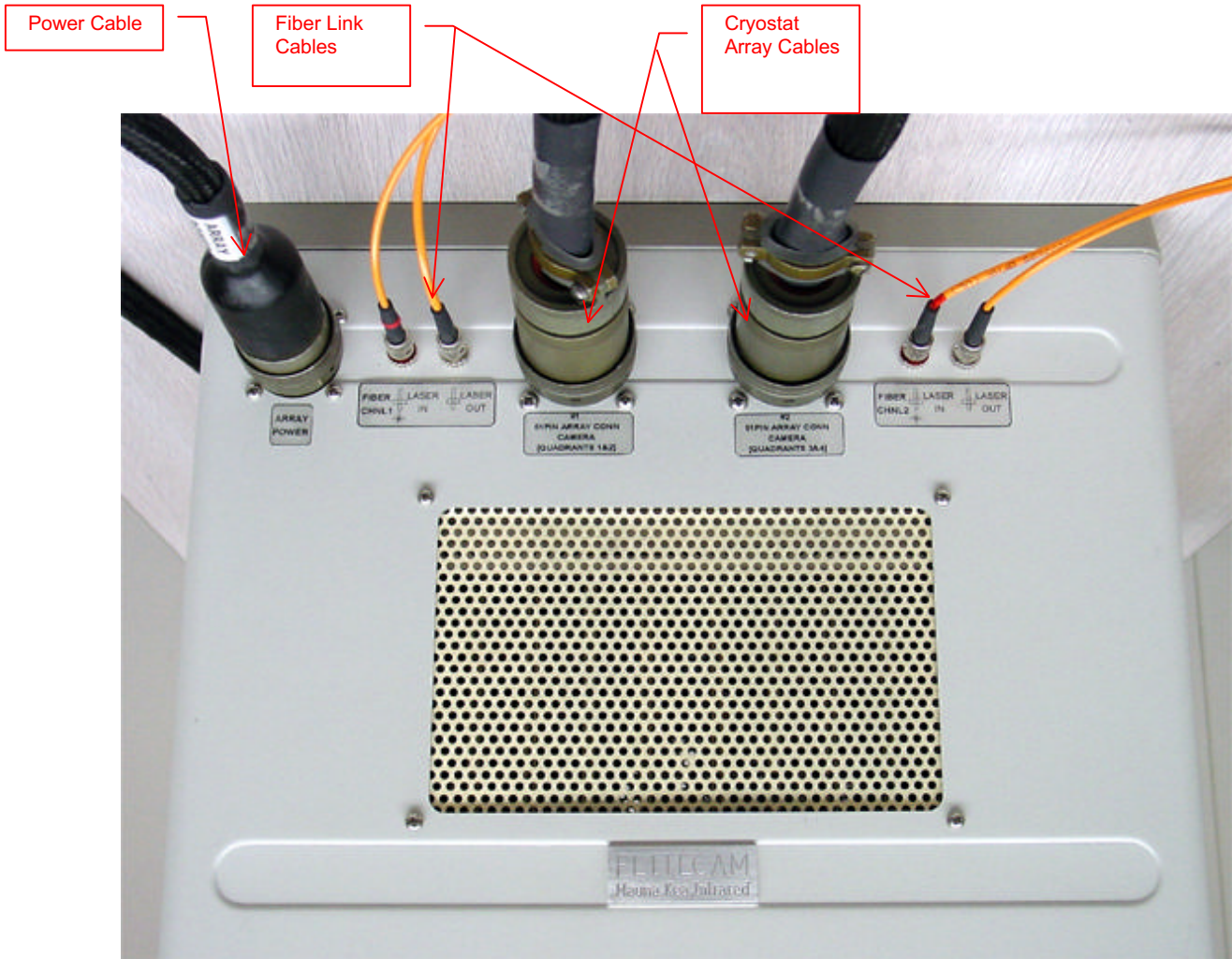

1.6.2 Fiber Links

The fiber links CHNL1 and CHNL2 connect via chassis mounted ST feedthrough connectors. Short jumper fiber cables complete the connections to the fiber board front panels.

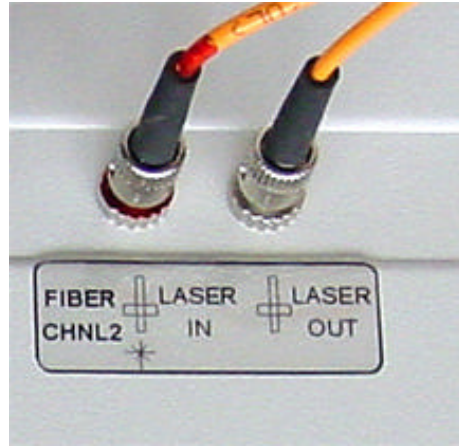
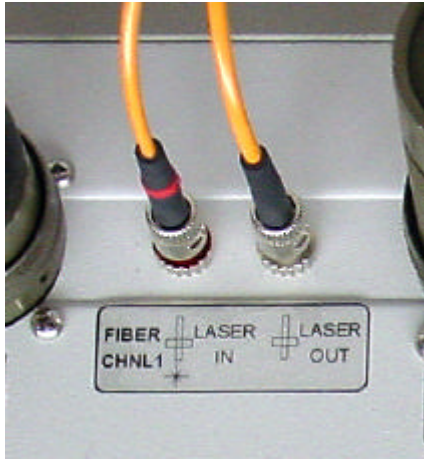

1.6.3 Array Cables

Connection to the internal cryostat electronics is made through two 61 pin low capacitance cables. These cables are fabricated from multiple coaxial cables. They mate with the two cryostat mounted hermetic connectors. *Note: FLITECAM has been provided with a twisted pair version of the cables for test purposes. These test cables do not have the same shielding level as coax cables. Cryostat image shown for reference purposes only.*

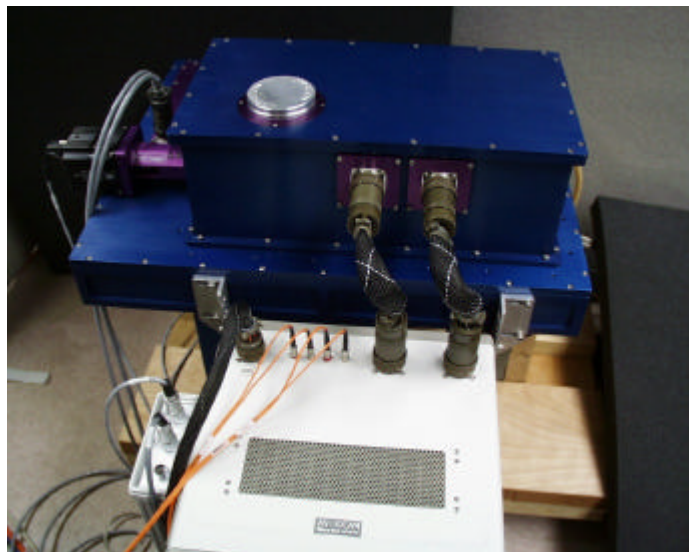
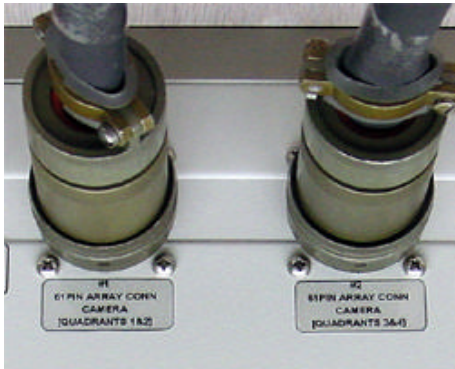

Rev 0.2 prerelease

1.6.4 Input Power Connection

A 16 pin power cable connects to a chassis mounted connector. It provides +5V,+15V,-15V and +24VDC supply power for the Cryostat Mounted Electronics.

